

» Thorax, Lunge

» Thorax, Lung

» Thorax, Poumon

» Toráico, Pulmón

» Torace, Polmone



**Rippenscheren**  
**Rib shears**  
*Costotomes*  
*Costótomos*  
*Costotomi*



1:2

220 mm – 8 ¾ "	15-101-220
----------------	------------



190 mm – 7 ½ "	15-102-190
230 mm – 9 "	15-102-230



**GLUCK**

220 mm – 8 ¾ "	15-103-220
----------------	------------



**STILLE** 1:2

210 mm – 8 ¼ "
15-107-210

**Rippenscheren**  
**Rib shears**

*Costotomes*  
*Costótomos*  
*Costotomi*



**BRUNNER**

1:3

320 mm – 12 ½ "	15-108-280	15-109-280
-----------------	------------	------------

für die rechte Hand  
for the right hand  
pour la main droite  
para la mano derecha  
per la mano destra

für die linke Hand  
for the left hand  
pour la main gauche  
para la mano izquierda  
per la mano sinistra



1:3

**SAUERBRUCH-FREY**

360 mm – 14 ¼ "	15-110-360
-----------------	------------

Rippenscheren  
*Rib shears*

*Costotomes*  
*Costótomos*  
*Costotomi*



1:3

**SAUERBRUCH**

260 mm – 10 ¼" 15-111-260



1:3

**BETHUNE**

340 mm – 13 ½" 15-112-340



1:3

**GIERTZ-STILLE**

270 mm – 10 ¾" 15-113-270



1:3

**LEBSCHER**

245 mm – 9 ¾" 15-114-245

**Rippensperrer**  
**Rib retractors**

*Ecarteurs des côtes*  
*Separadores costales*  
*Divaricatori costali*

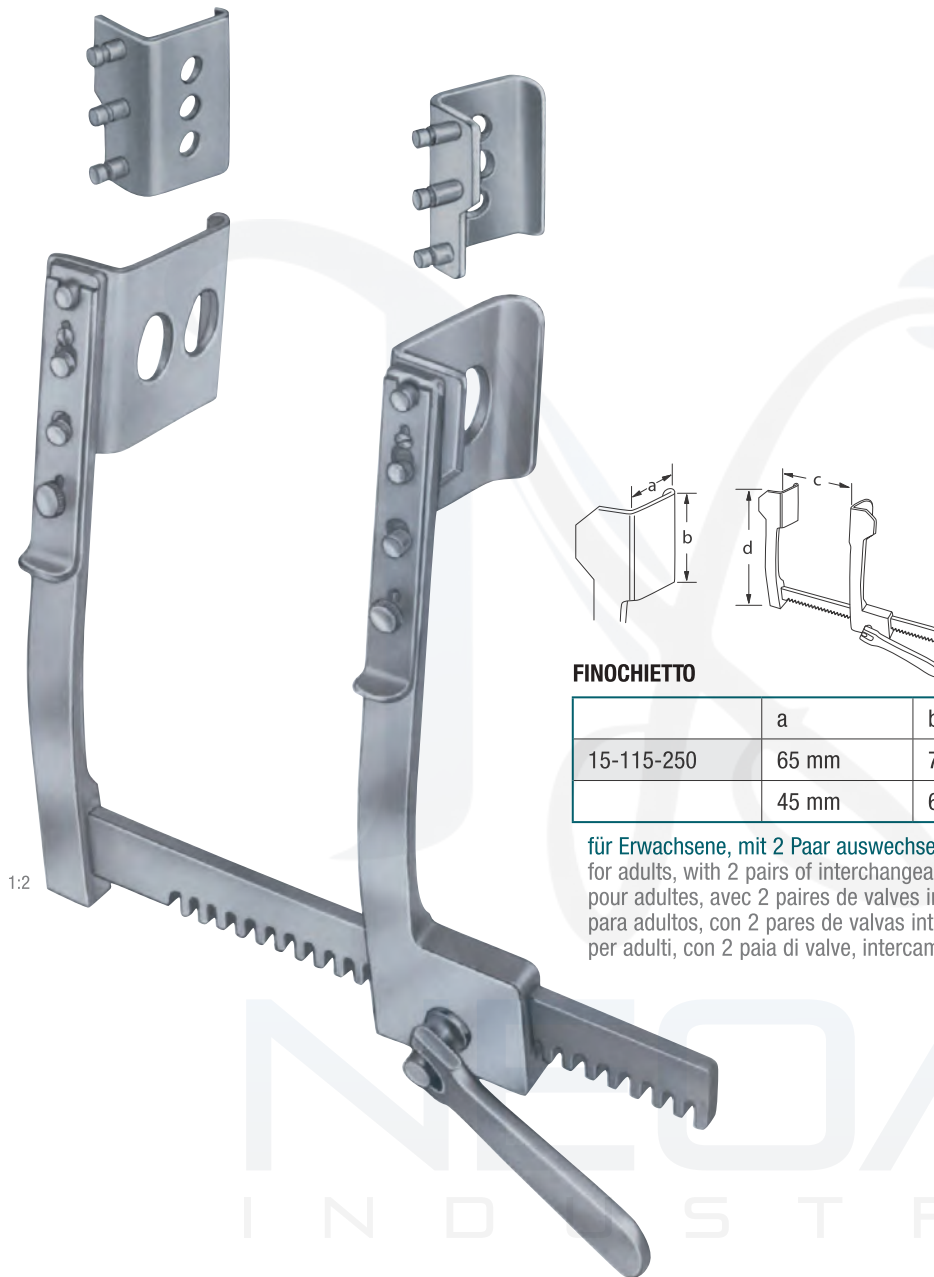

**FINOCHIETTO**

	a	b	c	d
15-115-250	65 mm	70 mm	200 mm	140 mm
	45 mm	65 mm		

für Erwachsene, mit 2 Paar auswechselbaren Valven, rostfrei  
for adults, with 2 pairs of interchangeable blades, stainless steel  
pour adultes, avec 2 paires de valves interchangeables, inoxydable  
para adultos, con 2 pares de valvas intercambiables, inoxidable  
per adulti, con 2 paia di valve, intercambiabili, inossidabile

**BABY-HAIGHT**

	a	b	c	d
15-116-090	28 mm	30 mm	85 mm	70 mm

rostfrei  
stainless steel  
acier inoxydable  
acero inoxidable  
acciaio inossidabile



**Rippensperrer**  
**Rib retractors**

*Ecarteurs des côtes*  
*Separadores costales*  
*Divaricatori costali*

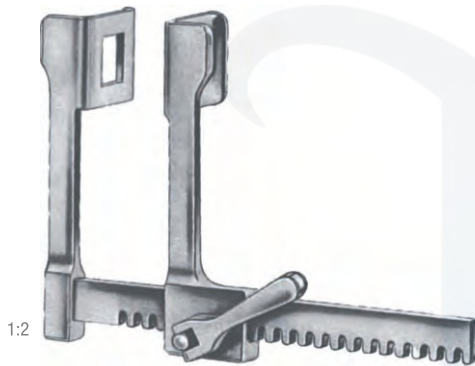
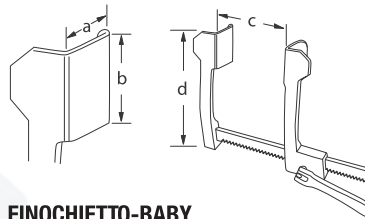

### FINOCHIETTO-BABY

	a	b	c	d
15-117-750	14 mm	15 mm	75 mm	55 mm

rostfrei  
stainless steel  
acier inoxydable  
acero inoxidable  
acciaio inossidabile

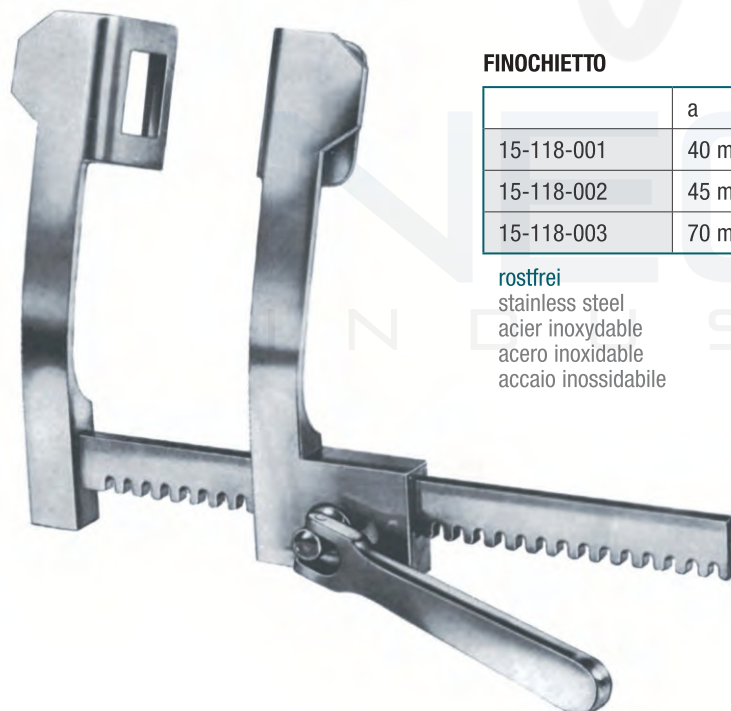

### FINOCHIETTO

	a	b	c	d
15-118-001	40 mm	40 mm	165 mm	110 mm
15-118-002	45 mm	65 mm	200 mm	140 mm
15-118-003	70 mm	65 mm	250 mm	140 mm

rostfrei  
stainless steel  
acier inoxydable  
acero inoxidable  
acciaio inossidabile

**Rippensperrer**  
**Rib retractors**

*Ecarteurs des côtes*  
*Separadores costales*  
*Divaricatori costali*

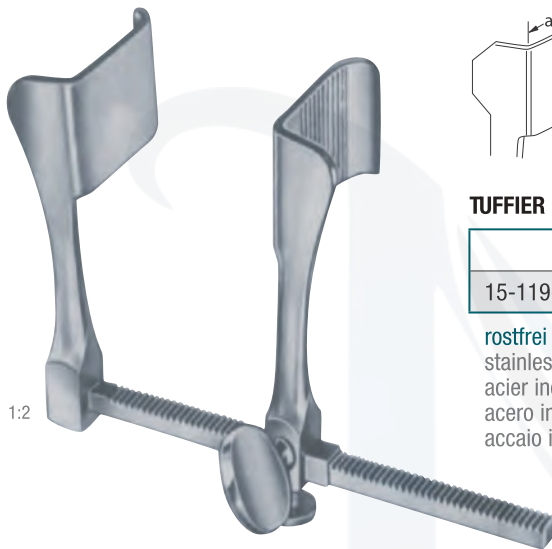

1:2

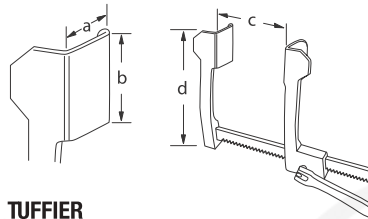

**TUFFIER**

	a	b	c	d
15-119-000	50 mm	45 mm	165 mm	110 mm

rostfrei  
stainless steel  
acier inoxydable  
acero inoxidable  
acciaio inossidabile



1:2

**DE BOER (STERNAL)**

	a	b	c	d
15-120-000	30 mm	100 mm	210 mm	185 mm

rostfrei  
stainless steel  
acier inoxydable  
acero inoxidable  
acciaio inossidabile

**Rippensperrer**  
**Rib retractors**

*Ecarteurs des côtes*  
*Separadores costales*  
*Divaricatori costali*

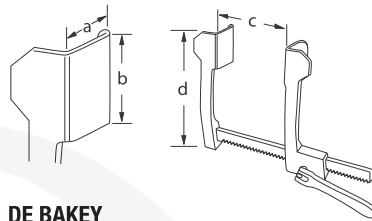

**DE BAKEY**

	a	b	c	d
15-121-000	30 mm	30 mm	150 mm	180 mm
	40 mm	40 mm		
	50 mm	50 mm		

**für Kinder, mit 3 Paar auswechselbaren Valven, rostfrei**  
for children, with 3 pairs of interchangeable blades, stainless steel  
pour enfants, 3 paires de valves, interchangeables, inoxydables  
para niños, 3 pares de valvas intercambiables, inoxidable  
per bambini, 3 paia di valve intercambiabili, inossidabile

	a	b
15-121-300	30 mm	30 mm
15-121-400	40 mm	40 mm
15-121-500	50 mm	50 mm
15-121-660	66 mm	66 mm

**Valven-Paar, rostfrei**  
Pair of blades, stainless steel  
Paire de valves, acier inoxydable  
Par de valvas, acero inoxidable  
Paia di valve, acciaio inossidabile



15-121-090
------------

**Sperrer allein**  
retractor only  
ecarteur seul  
separador suelto  
divaricatore solo



**Rippensperrer**  
**Rib retractors**

*Ecarteurs des côtes*  
*Separadores costales*  
*Divaricatori costali*

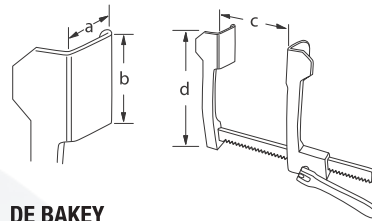

**DE BAKEY**

	a	b	c	d
15-122-000	30 mm	30 mm	200 mm	225 mm
	50 mm	80 mm		
	60 mm	60 mm		

für Erwachsene, mit 3 Paar auswechselbaren Valven, rostfrei  
for adults, with 3 pairs of interchangeable blades, stainless steel  
pour adultes, 3 paires de valves, interchangeables, inoxydable  
para adultos, 3 pares de valvas intercambiables, inoxidable  
per adulti, 3 paia di valve intercambiabili, inossidabile

	a	b
15-122-300	30 mm	30 mm
15-122-400	40 mm	100 mm
15-122-500	50 mm	80 mm
15-122-600	60 mm	60 mm
15-122-660	66 mm	66 mm
15-122-800	80 mm	60 mm

Valven-Paar, rostfrei  
Pair of blades, stainless steel  
Paire de valves, acier inoxydable  
Par de valvas, acero inoxidable  
Paia di valve, acciaio inossidabile



	15-122-220
--	------------

Sperrer allein  
retractor only  
ecarteur seul  
separador suelto  
divaricatore solo

**Rippensperrer**  
**Rib retractors**

*Ecarteurs des côtes*  
*Separadores costales*  
*Divaricatori costali*



### MERCEDES THORAXSPERRER

	a	b	c	d
15-123-001	45 mm	68 mm	285 mm	185 mm
	70 mm	75 mm		

für Erwachsene, mit 2 Paar auswechselbaren Valven mit Kugelschnellverschluss, rostfrei  
for adults, with 2 pairs of interchangeable blades with ball snap system, stainless steel  
pour adultes, avec 2 paires de valves interchangeables fermeture à boules, inoxydable  
para adultos, con 2 pares de valvas intercambiables fijación con bolas, inoxidable  
per adulti, con 2 paia di valve intercambiabili, inossidabile

	a	b
15-123-003	45 mm	68 mm
15-123-004	70 mm	75 mm

**Valven-Paar, rostfrei**  
Pair of blades, stainless steel  
Paire de valves, acier inoxydable  
Par de valvas, acero inoxidable  
Paia di valve, acciaio inossidabile

15-123-001

**Sperrer allein**  
Retractor only  
Ecarteur seul  
Separador sólo  
Divaricatore solo

**i.M.A. Thoraxsperrer**  
**Thoracic and I.M.A. retractor**

*Ecarteur thoracique et I.M.A.*  
*Separador torácico e I.M.A.*  
*Divaricatore per il torace ed I.M.A.*

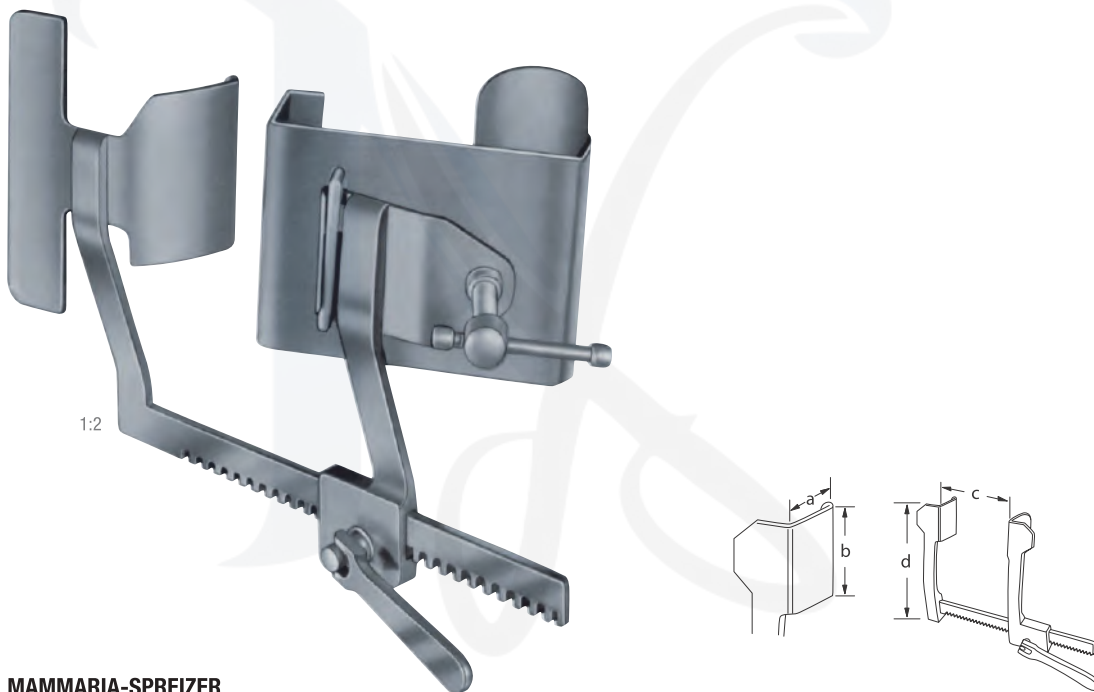

### MAMMARIA-SPREIZER

	a	b	c	d
15-124-000	55 mm	100 mm	170 mm	130 mm

mit abnehmbarer Kippvalve und Stellschraube zum Anheben der Brustwand bei der Mammaria-Dissektion, rostfrei  
 with detachable tilting IMA-blade and set-screw to lift the sternal margin for the dissection of the IMA, stainless steel  
 avec valve mobile, démontable, écrou pour soulever le thorax pendant des dissections IMA, inoxydable  
 con valva móvil y desmontable, rosca para levantar el tórax durante la disección IMA, inoxidable  
 con valva smontabili e vite di fissaggio per alzare lo sterno per dissezione IMA, inossidabile

Lungenspatel – Rippenkontraktoren  
*Lung spatula – Rib contractors*

*Spatules pulmonaires – Rapprocheurs*  
*Espátula pulmonar – Aproximadores para costillas*  
*Spatole per polmone – Approssimatori costali*



**ALLISON**

300 mm – 12 "	15-125-300
320 mm – 12 ½ "	15-126-000



**BAILEY-BABY**

1:2

140 mm – 5 ½ "	15-127-140
----------------	------------



**BAILEY**

1:2

160 mm – 6 ¼ "	15-128-160
----------------	------------

Rippenkontraktoren  
*Rib contractors*

*Rapprocheurs*  
*Aproximadores para costillas*  
*Approssimatori costali*



**LEMMON**

145 mm – 5 ¾ "	15-129-140
180 mm – 7 "	15-129-180



**BAILEY-GIBBON**

1:2

160 mm – 6 ¼ "	15-130-160
----------------	------------



**SELLORS**

1:2

190 mm – 7 ½ "	15-131-190
----------------	------------

Rippensperrer  
Rib retractors

Ecarteurs des côtes  
Separadores costales  
Divaricatori costali

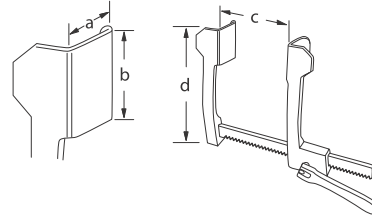

### BURFORD 8"

Aluminium				
	a	b	c	d
15-132-001	45 mm	62 mm	165 mm	200 mm
	65 mm	62 mm		

für Erwachsene, mit 2 Paar auswechselbaren Valven  
for adults, with 2 pairs of interchangeable blades  
pour adultes, avec 2 paires de valves interchangeables  
para adultos, con 2 pares de valvas intercambiables  
per adulti, con 2 paia di valve intercambiabili

### BURFORD 10"

Aluminium				
	a	b	c	d
15-132-002	45 mm	62 mm	250 mm	200 mm
	65 mm	62 mm		

für Erwachsene, mit 2 Paar auswechselbaren Valven  
for adults, with 2 pairs of interchangeable blades  
pour adultes, avec 2 paires de valves interchangeables  
para adultos, con 2 pares de valvas intercambiables  
per adulti, con 2 paia di valve intercambiabili

### BURFORD 12"

Aluminium				
	a	b	c	d
15-132-003	45 mm	62 mm	290 mm	200 mm
	62 mm	62 mm		

für Erwachsene, mit 2 Paar auswechselbaren Valven  
for adults, with 2 pairs of interchangeable blades  
pour adultes, avec 2 paires de valves interchangeables  
para adultos, con 2 pares de valvas intercambiables  
per adulti, con 2 paia di valve intercambiabili

### BURFORD

Aluminium				
	a	b	c	d
15-133-001	30 mm	42 mm	130 mm	117 mm
	41 mm	42 mm		

für Kinder, mit 2 Paar auswechselbaren Valven  
for children, with 2 pairs of interchangeable blades  
pour enfants, avec 2 paires de valves interchangeables  
para niños, con 2 pares de valvas intercambiables  
per bambini, con 2 paia di valve intercambiabili



Rippensperrer  
*Rib retractors*

*Ecarteurs des côtes*  
*Separadores costales*  
*Divisori costali*

TC

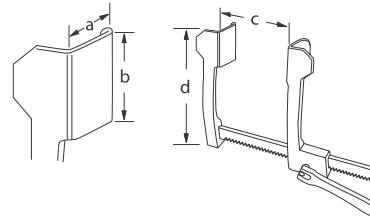

**FINOCHIETTO**

Aluminium	a	b	c	d
15-134-001	40 mm	45 mm	135 mm	110 mm

kleines Modell, auch für Kinder geeignet  
small size, for children too  
petit modèle, également pour enfants  
modelo pequeño, también para niños  
modello piccolo, pure per bambini

**FINOCHIETTO**

Aluminium	a	b	c	d
15-134-002	52 mm	65 mm	175 mm	140 mm

mittleres Modell, für Erwachsene  
medium size, for adults  
moyen modèle, pour adultes  
modelo medio, para adultos  
modello medio, per adulti



**FINOCHIETTO**

Aluminium	a	b	c	d
15-134-003	85 mm	65 mm	175 mm	140 mm

grosses Modell, für Erwachsene  
large size, for adults  
grand modèle, pour adultes  
modelo grande, para adultos  
modello grande, per adulti

1:2

**FINOCHIETTO-  
INFANT**

Aluminium	a	b	c	d
15-135-010	27 mm	30 mm	95 mm	80 mm

für Kinder  
for children  
pour enfants  
para niños  
per bambini

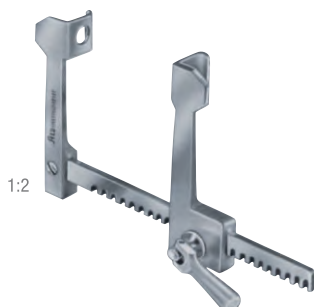

1:2

**FINOCHIETTO-  
BABY-HAIGHT**

Aluminium	a	b	c	d
15-136-750	15 mm	15 mm	75 mm	55 mm

für Säuglinge  
for infants  
pour nourissons  
para lactantes  
per lattanti

### Rippensperrer Rib retractors

*Ecarteurs des côtes*  
*Separadores costales*  
*Divaricatori costali*

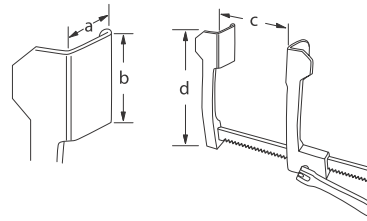

#### COOLEY

Aluminium	a	b	c	d
15-137-090	35 mm	100 mm	180 mm	180 mm

für Erwachsene  
for adults  
pour adultes  
para adultos  
per adulti

#### COOLEY

Aluminium	a	b	c	d
15-137-095	35 mm	115 mm	230 mm	205 mm

extra gross, für Erwachsene  
extra large, for adults  
extra grand, pour adultes  
extra grande, para adultos  
extra grande, per adulti

#### COOLEY

Aluminium	a	b	c	d
15-137-030	21 mm	44 mm	150 mm	145 mm

für Erwachsene, Standardgröße, modifiziert  
for adults, standard size, modified  
pour adultes, standard, modifié  
para adultos, estandard, modificado  
per adulti, standard, modificato

#### COOLEY

Aluminium	a	b	c	d
15-137-020	15 mm	30 mm	140 mm	110 mm

für Kinder, modifiziert  
for children, modified  
pour enfants, modifié  
para niños, modificado  
per bambini, modificato





Rippensperrer  
Rib retractors

Ecarteurs des côtes  
Separadores costales  
Divaricatori costali

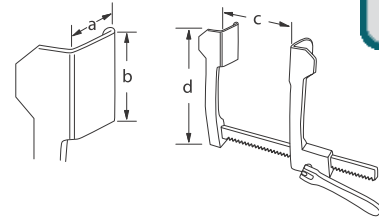

### COOLEY

Aluminium	a	b	c	d
15-137-070	30 mm	35 mm	140 mm	110 mm

für Kinder  
for children  
pour enfants  
para niños  
per bambini

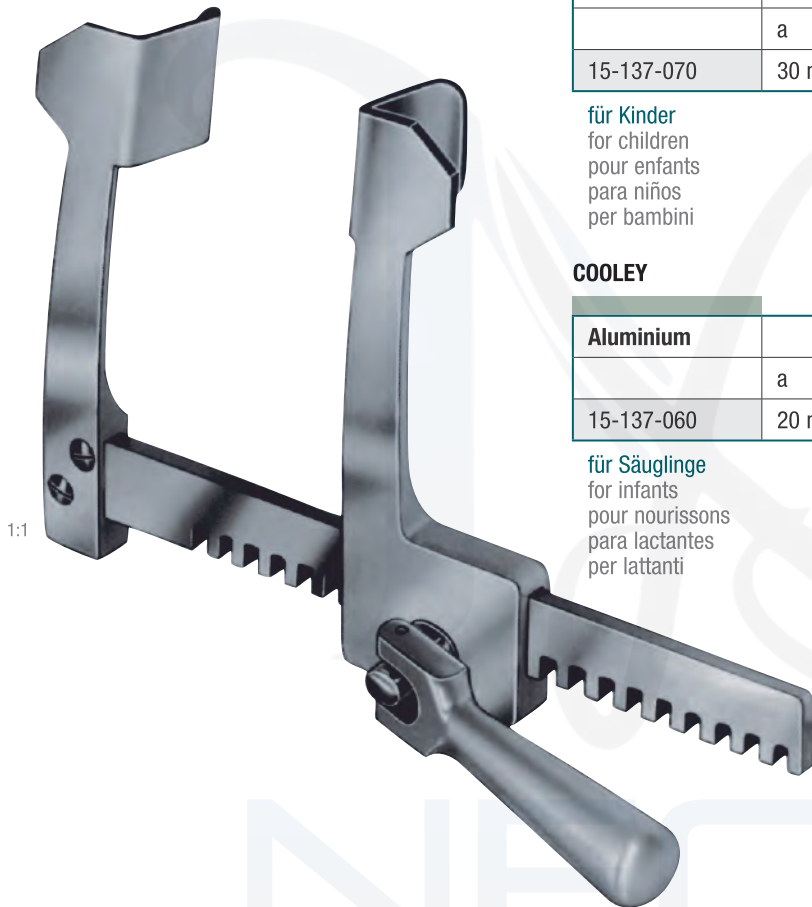

### COOLEY

Aluminium	a	b	c	d
15-137-060	20 mm	25 mm	100 mm	80 mm

für Säuglinge  
for infants  
pour nourissons  
para lactantes  
per lattanti



### COOLEY

Aluminium	a	b	c	d
15-137-000	12mm	15 mm	70 mm	55 mm

für Neugeborene  
for newbornes  
pour nouveau-nés  
para recién nacidos  
per neonati

### Rippensperrer Rib retractors

*Ecarteurs des côtes*  
*Separadores costales*  
*Divaricatori costali*



#### COOLEY

Aluminium				
	a	b	c	d
15-137-115	15 mm	30 mm	115 mm	80 mm

für Kinder, Sternotomiespreizer, leicht aber trotzdem kräftig  
for children, sternal spreader, light-weight but sturdy  
pour enfants, écarteur sternal, léger mais fort  
para niños, separador e sternal, ligero y fuerte  
per bambini, divaricatore sternale, leggero ma forte

#### COOLEY

Aluminium				
	a	b	c	d
15-137-010	12 mm	17 mm	95 mm	55 mm

für Neugeborene  
for newbornes  
pour nouveau-nés  
para recién nacidos  
per neonati

#### COOLEY

Aluminium				
	a	b	c	d
15-137-050	15 mm	20 mm	100 mm	80 mm

für Säuglinge, Sternotomiespreizer mit Dornen  
for infants, sternal spreader with prongs  
pour nourissons, écarteur sternal avec poinçons  
para lactantes, separador e sternal con espigas  
per lattanti, divaricatore sternale con spine

**Rippensperrer**  
**Rib retractors**

*Ecarteurs des côtes*  
*Separadores costales*  
*Divaricatori costali*

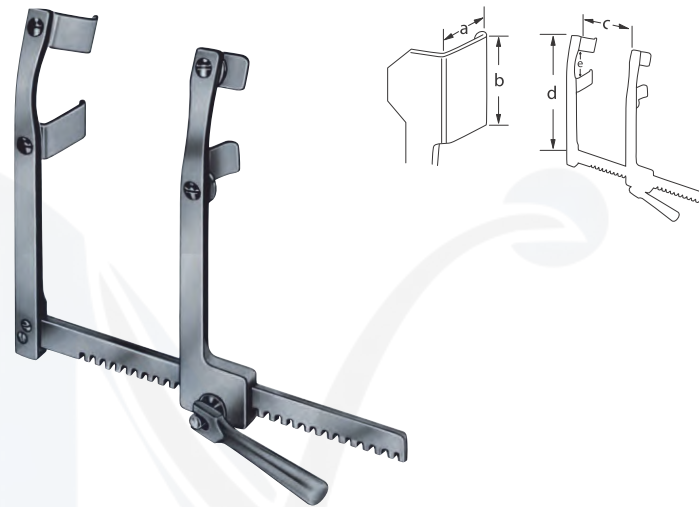

**MORSE STERNAL**

Aluminium				
	a	b	c	d
15-138-001	20 mm	20 mm	155 mm	120 mm

mit 2 Paar beweglichen Valven, für Kinder, Biegung der Spreizarme zwischen den Valven  
with 2 pairs movable blades, for children, arms curved between blades  
avec 2 paires de valves mobiles, pour enfants, courbure entre les valves  
con 2 pares de valvas móviles, para niños, curvado entre las valvas  
con 2 paia di valve mobili, per bambini, branche curvate

**MORSE STERNAL**

Aluminium				
	a	b	c	d
15-138-002	20 mm	28 mm	210 mm	155 mm

mit 2 Paar beweglichen Valven, für Erwachsene, Biegung der Spreizarme zwischen Zahnstange und Valven  
with 2 pairs movable blades, for adults, arms curved between rack and blades  
avec 2 paires de valves mobiles, pour adultes, courbure entre la base et les valves  
con 2 pares de valvas móviles, para adultos, curvado entre la base y las valvas  
con 2 paia di valve mobili, per adulti, branche curvate

**MORSE STERNAL**

Aluminium				
	a	b	c	d
15-138-003	40 mm	28 mm	155 mm	120 mm

mit 2 Paar beweglichen Valven, für Kinder, Biegung der Spreizarme zwischen Zahnstange und Valven  
with 2 pairs movable blades, for children, arms curved between rack and blades  
avec 2 paires de valves mobiles, pour enfants, courbure entre la base et les valves  
con 2 pares de valvas móviles, para niños, curvado entre la base y las valvas  
con 2 paia di valve mobili, per bambini, branche curvate

Rippensperrer  
*Rib retractors*

*Ecarteurs des côtes*  
*Separadores costales*  
*Divaricatori costali*



### MORSE-FAVALORO STERNAL

Aluminium	a	b	c	d
15-138-004	40 mm	20 mm	155 mm	175 mm

mit 2 Paar beweglichen Valven, für Erwachsene, Biegung der Spreizarme zwischen den Valven  
with 2 pairs movable blades, for adults, arms curved between blades  
avec 2 paires de valves mobiles, pour adultes, courbure entre les valves  
con 2 pares de valvas móviles, para adultos, curvado entre las valvas  
con 2 paia di valve mobili, per adulti, branche curvate

### MORSE-FAVALORO STERNAL

Aluminium	a	b	c	d
15-138-005	17 mm	22 mm	160 mm	120 mm

mit 2 Paar beweglichen Valven, für Kinder, Biegung der Spreizarme zwischen den Valven  
with 2 pairs movable blades, for children, arms curved between blades  
avec 2 paires de valves mobiles, pour enfants, courbure entre les valves  
con 2 pares de valvas móviles, para niños, curvado entre las valvas  
con 2 paia di valve mobili, per bambini, branche curvate

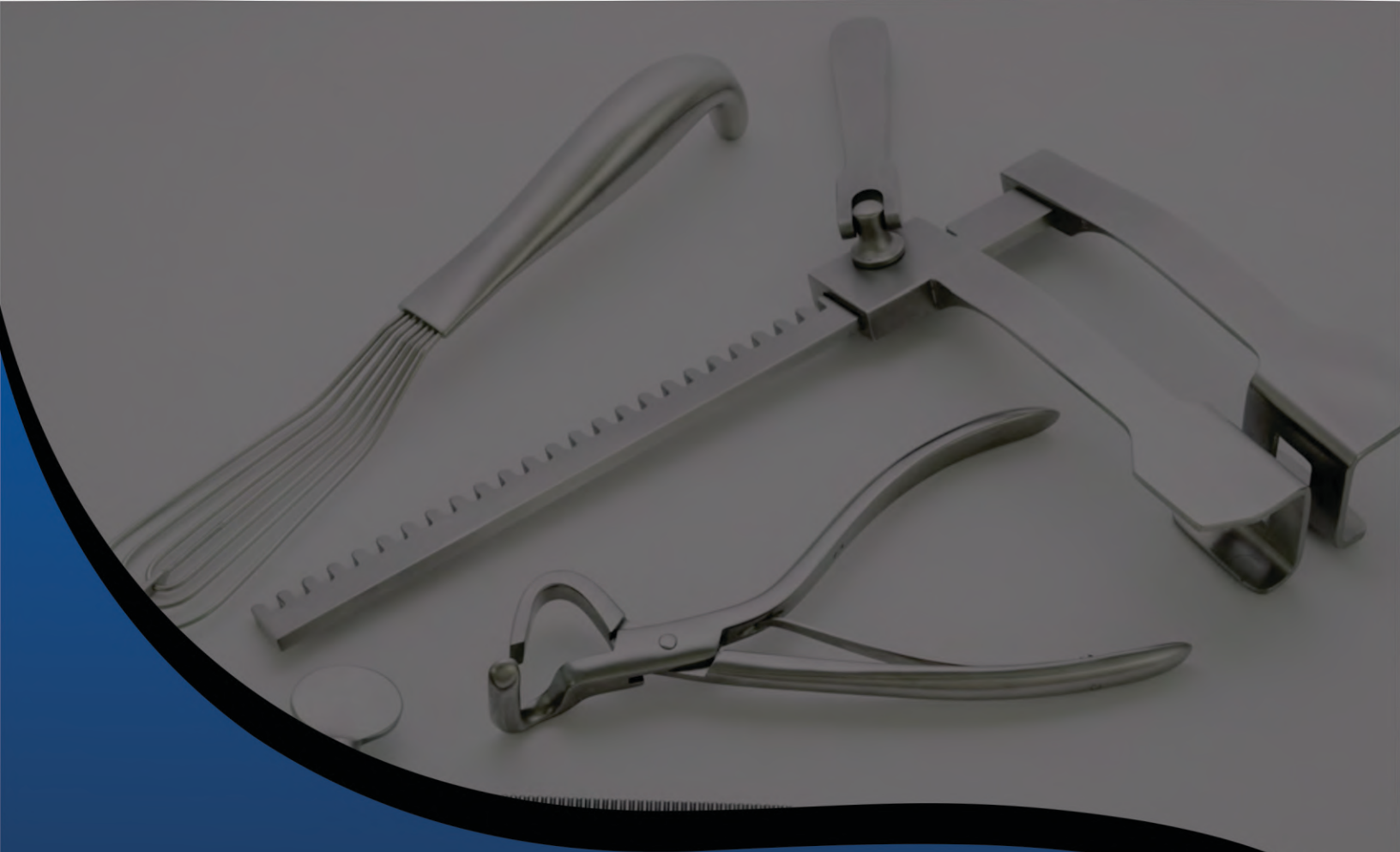

Manufacturer & Supplier Premium Quality Surgical, Dental, Podiatry, Pet Grooming and Beauty Care Instruments.

**USA Address:**

📍 5900 Balcones Drive # 16244  
Austin TX, USA 78731.  
☎ +1 (917) 773 3694  
📞 **uk:** +44 7871 836765  
✉ info@neoindustry.com  
neoaindustry4@gmail.com  
🌐 www.neoindustry.com

**Main Head Office:**

📍 Roars Road New Miana Pura  
West, Sialkot 51310 Pakistan.  
☎ +92 322 5587688  
📞 +92 322 5587688  
✉ info@neoindustry.com  
neoaindustry4@gmail.com  
🌐 www.neoindustry.com

